

Spectralink DECT Server 2500

Installation Guide

Copyright Notice

© 2013 Spectralink Corporation All rights reserved. Spectralink™, the Spectralink logo and the names and marks associated with Spectralink's products are trademarks and/or service marks of Spectralink Corporation and are common law marks in the United States and various other countries. All other trademarks are property of their respective owners. No portion hereof may be reproduced or transmitted in any form or by any means, for any purpose other than the recipient's personal use, without the express written permission of Spectralink.

All rights reserved under the International and pan-American Copyright Conventions. No part of this manual, or the software described herein, may be reproduced or transmitted in any form or by any means, or translated into another language or format, in whole or in part, without the express written permission of Spectralink Corporation.

Do not remove (or allow any third party to remove) any product identification, copyright or other notices.

Notice

Spectralink Corporation has prepared this document for use by Spectralink personnel and customers. The drawings and specifications contained herein are the property of Spectralink and shall be neither reproduced in whole or in part without the prior written approval of Spectralink, nor be implied to grant any license to make, use, or sell equipment manufactured in accordance herewith.

Spectralink reserves the right to make changes in specifications and other information contained in this document without prior notice, and the reader should in all cases consult Spectralink to determine whether any such changes have been made.

NO REPRESENTATION OR OTHER AFFIRMATION OF FACT CONTAINED IN THIS DOCUMENT INCLUDING BUT NOT LIMITED TO STATEMENTS REGARDING CAPACITY, RESPONSE-TIME PERFORMANCE, SUITABILITY FOR USE, OR PERFORMANCE OF PRODUCTS DESCRIBED HEREIN SHALL BE DEEMED TO BE A WARRANTY BY SPECTRALINK FOR ANY PURPOSE, OR GIVE RISE TO ANY LIABILITY OF SPECTRALINK WHATSOEVER.

Spectralink Corporation,
2550 55th Street,
Boulder CO 80301,
USA

Spectralink Europe ApS,
Langmarksvej 34,
8700 Horsens,
Denmark

Contents

Spectralink DECT Server 2500 Installation 3

Installing the Spectralink DECT Server 2500	3
Specifications	3
Spectralink DECT Server 2500 Components	4
Connections	6
General Installation Information	7
Installing the Spectralink DECT Server 2500 on a Flat Surface	7
Installing the Spectralink DECT Server 2500 on a Wall	8
Connecting the Spectralink DECT Server 2500 Cables	10
Installing Interface Cards and CPU Cards	11

Replacing Components 16

Component Replacement	16
Component Replacement Precautions	16

Regulatory Notices 18

International Regulatory and Product Information	18
United States Federal Communication Commission (FCC)	18
United States Safety Construction Details:	18
CE Mark R&TTE Directive	18
Canadian Department of Communications	19
Important Safety Instructions and Product Information	19
Warning	20
Intrinsic safety	20
Exposure to Sunlight, Heat and Moisture	20
Spare Parts and Accessories	20
RF Compliance Information	21
NOTICES	21
Spectralink® Product Warranty Statement	21
END-USER LICENSE AGREEMENT FOR SPECTRALINK SOFTWARE	23

Appendix A: RJ45 Wiring 28

Appendix B: Cable Connections 29

Analogue Interface Card 29
Base Station Interface Card 29
. 30
Base Station Interface Card 30
RJ45 Pins 31

Tables 32

Figures 33

Chapter 1: Spectralink DECT Server 2500 Installation

This guide describes how you install the Spectralink DECT Server 2500.

Installing the Spectralink DECT Server 2500

The Spectralink DECT Server 2500 can be installed on a flat surface or on a wall. Before you start the installation, place the Spectralink DECT Server 2500 on a stable flat surface in the selected location, and inspect the package for any damage and report it to the reseller or distributor immediately.



Important

Please review all the safety instructions for important safety and regulatory information

Specifications

Table 1 Physical Dimensions

Physical dimensions	
Height	177mm
Width	194 mm
Depth	328 mm
Weight	1.16 kg (excl. power supply)

Table 2 Power Supply

Power supply	
AC Input	100-240 VAC, 50/60 Hz

Table 3 Power Consumption

Power consumption	
Typical AC Power Consumption	45 Watt
Max. AC Power Consumption	Max 60 Watt

Table 4 Environment

Environment	
Operating temperature	0°C - 40°C (22° - 104°F)
Storage temperature	-30°C - 70°C (40° - 158°F)
Relative humidity	20% - 80% Non condensing
Operating altitude	Up to 2000 m (6,500 ft)
Operating ESD level	4 KV

Spectralink DECT Server 2500 Components

The following table contains all Spectralink DECT Server 2500 parts and their part numbers.

Picture	Description	Part Numbers
	Base Station Interface card (8 base stations)	0233 9100
	Analogue Interface card (16 lines)	0233 9200
	Analogue Interface card (8 lines)	0233 9220
	CPU card with link option	0233 9800 Includes two terminator connectors.

Picture	Description	Part Numbers
	CPU card without link option	0233 9900
	Media Resource Card	0233 9700
	Mains adaptor	8476 9904 - AV only
	EU mains cable	8468 7013
	UK mains cable	8468 7014
	US mains cable	8468 7015
	RS232 cable	13281100

Connections

Figure 1 CPU Card Connections

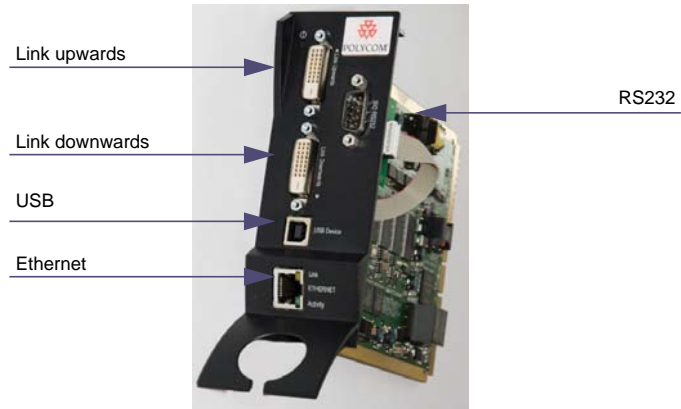

Note

Link connections must not be left open. You have to either plug in a link cable or a terminator connector for protection and for stable functionality.

Figure 2 RJ45 Connections for Base Stations

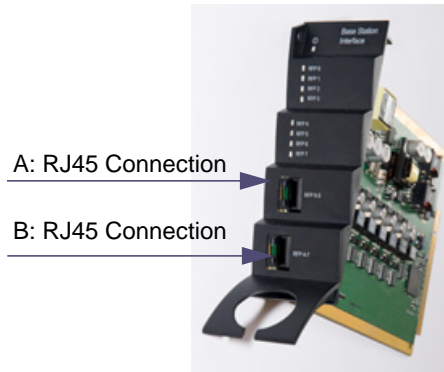

Figure 3 RJ45 Connections for AB Lines

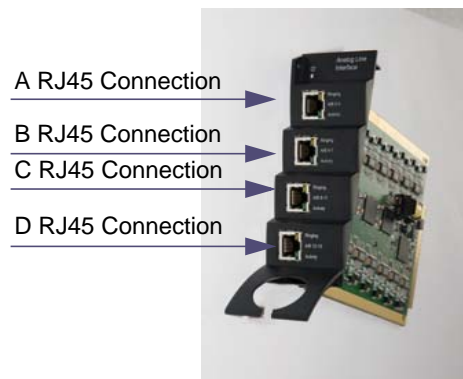
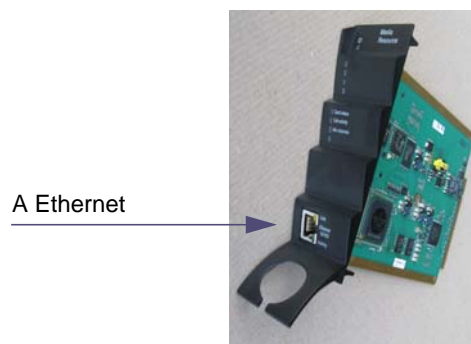

Figure 4 Media Resource Card Connection



General Installation Information

General Mounting Safety Precautions



Important

Electrical shock hazards from the telecommunication network and AC mains are possible with this equipment. To minimize risk to service personnel and users, the system must be connected to an outlet with a third-wire earth connection.

- Keep the area around the Spectralink DECT Server 2500 clean and free of clutter.
- Decide on a suitable surface that will hold the Spectralink DECT Server 2500 unit. It should be situated in a clean, dry, and dust-free area that is well ventilated. Avoid areas where heat, electrical noise, and electromagnetic fields are generated.
- Place it near an earthed power outlet.

Installing the Spectralink DECT Server 2500 on a Flat Surface

Before you start installation, take notice of the following safety precautions.

- Ensure the surface can support the weight of the unit.
- Never install the Spectralink DECT Server 2500 on the floor.
- Never place anything on top of the Spectralink DECT Server 2500. The top plate must be free to allow sufficient cooling.

To Install the Spectralink DECT Server 2500 on a Flat Surface

- 1** Remove the Spectralink DECT Server 2500 from its package.
- 2** Before placing the unit, carefully turn it upside down and mount the four rubber pads supplied in the package. One must be placed at each corner of the bottom plate.
- 3** Place it on a clean, flat, horizontal surface.

Installing the Spectralink DECT Server 2500 on a Wall

Before you start installation, take notice of the following safety precautions.

- Ensure the wall quality is good enough for holding the unit. Avoid high-porous surfaces, joints and similar.
- Never use countersunk screws.
- Leave at least 10 centimeter of free air above the unit for ventilation.

Mount the Spectralink DECT Server 2500 securely using two screws. Use wall plugs, expansion bolts or other appropriate fastening methods in relation to the wall material. Remove any drilling dust.

Figure 5 Wall mounting method 1

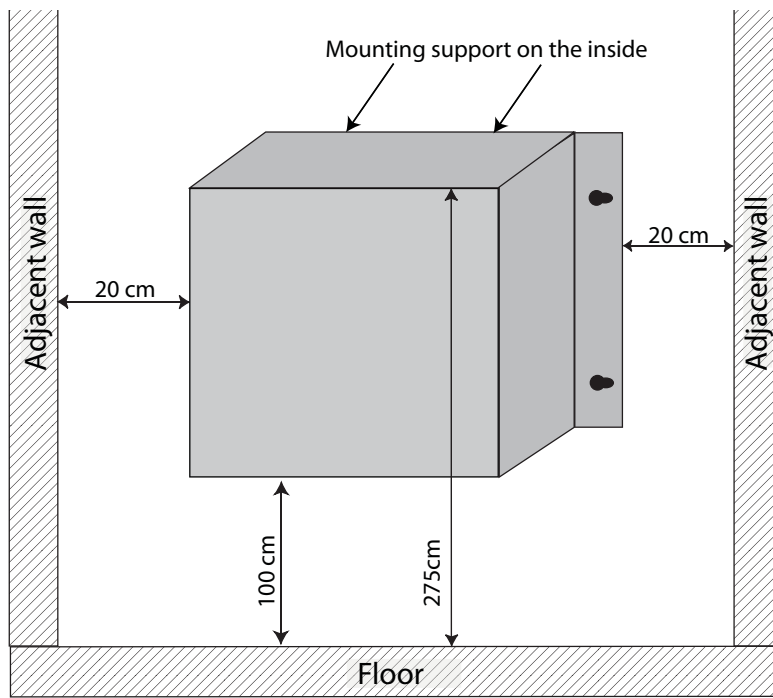

Figure 6 Wall mounting method 2

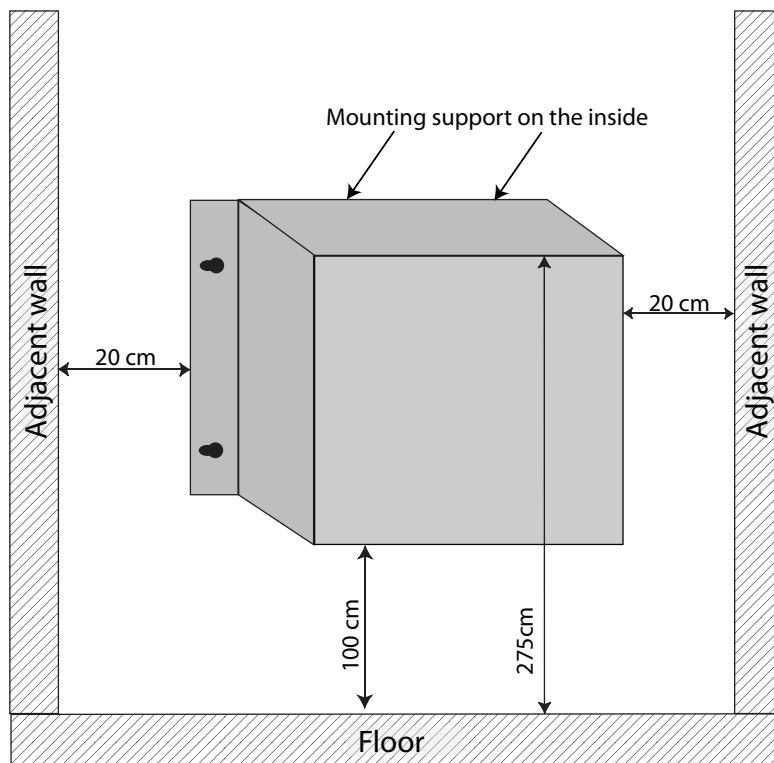
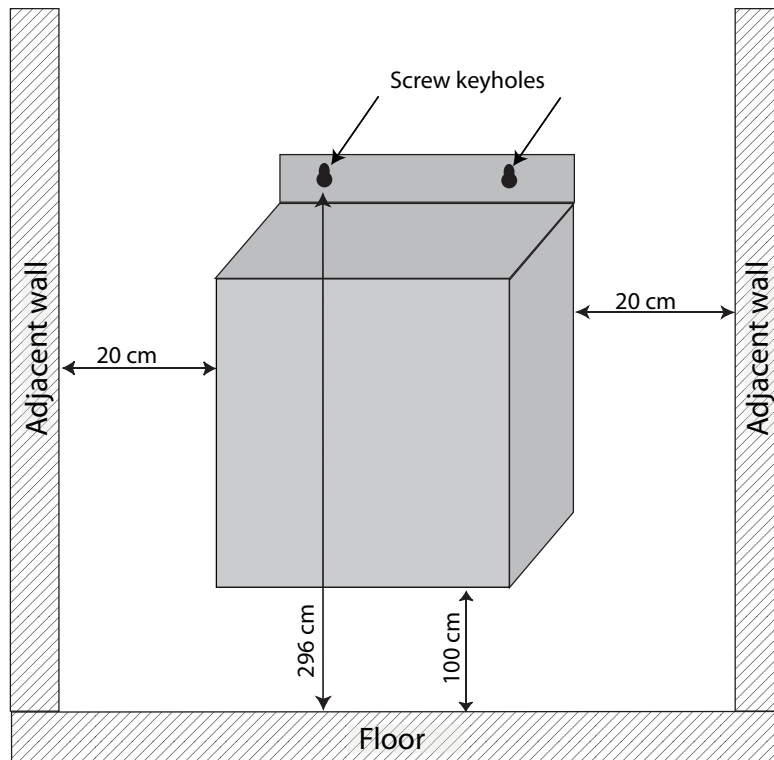

Figure 7 Wall mounting method 3

Connecting the Spectralink DECT Server 2500 Cables

When the Spectralink DECT Server 2500 has been mounted, the cables can be connected.

Cable Safety Precautions

Before you connect the cables, ensure to take the following electrical safety precautions.

- Always use an earthed socket for power.
- Use a power cord with protective earth (PE) connection suitable for the country where it is being used and with the appropriate local approvals.
- Power supply cables must be connected prior to connecting any interface cables.
- The interface cables must be removed before any interface card is removed or replaced.
- When unplugging power, unplug AC mains power first before unplugging the power connector from the Spectralink DECT Server 2500.
- The AC adapters must never be hanging by their own weight in the AC mains connector or the output connector.

To Connect Power Cable

The Spectralink DECT Server 2500 has one power plug on the back panel.

- 1 Plug a suitable power cord into the AC power adapter.
- 2 Insert the AC power adapter output connector firmly into the socket on the Spectralink DECT Server 2500 so that the retention clip snaps to the plug.
- 3 Plug the AC power adapter into mains.
- 4 When powering down the unit, the power connector must be unplugged to ensure the unit is completely powered off.

Installing Interface Cards and CPU Cards

Before you install an interface or a CPU card ensure to take the following precautions.

Safety Precautions

Cards contain static sensitive circuitry and may be destroyed or damaged by electrostatic discharge (ESD).

- Make sure you re using proper ESD equipment to prevent damage to the system.
- Fill all empty slots with blanking front plates to close the front.

To Install Interface Cards

- 1 With two hands, gently slide the interface card into the unit. Give it a gentle push on the last centimeter so that it enters the backplane connector properly.

Avoid pushing on the front connectors - push only on the plastic parts at the top and bottom.

Figure 8 Installing Interface Cards



- 2 Plug the interface cables into the card as described in [Connecting Interface Cables](#).

To Install CPU Cards

- 1 Ensure that the Spectralink DECT Server 2500 is powered off completely.
- 2 With two hands, gently slide the card into the unit. Give the card a gentle push on the last centimeter so that it enters the backplane connector properly.

Avoid pushing on the front connectors - push only on the plastic parts at the top and bottom.

Figure 9 Installing CPU card



- 1 Plug the interface cables into the card as described in [Connecting Interface Cables](#).
- 2 Connect the Spectralink DECT Server 2500 to a PC using the RS232 cable.
- 3 Connect the power and reboot the unit.

Connecting Interface Cables

The front interface of the Spectralink DECT Server 2500 is provided with connectors for the different interfaces provided. Please see the Spectralink DECT Server 2500 Configuration Guide for the actual pin-out of the different connectors.

The cables can be harnessed in two ways as shown in the following figures depending on the installation requirements.

Figure 10 *Harnessing cables to the back and out*



Figure 11 *Harnessing cables to the side and out.*



Regardless of which way is used for harnessing, you must guide the cables through the opening in the plastic front. This ensures safe retention of the cable.

Chapter 2: Replacing Components

The Spectralink DECT Server 2500 is designed to minimize down-time. Several components can be replaced while the system is up.

Component Replacement

The following components are hot-swappable:

- Interface cards
- AC adapters

The following require a power down of the system:

- Backplane
- CPU card

Before replacing any components, take notice of the component replacement precautions.

Component Replacement Precautions

- Cards contain static sensitive circuitry and may be destroyed or damaged by electrostatic discharge (ESD.)
- All maintenance tasks must be performed by qualified, authorized personnel only.
- Use only original replacement parts.
- Make sure you are using proper ESD equipment, to prevent damage to the system.
- Fill all empty slots with blanking front plates to close the front.

To Replace a New Hot-swappable Card

- 1 Ensure the Spectralink DECT Server 2500 unit is properly earthed.
- 2 Unplug all interface cables on the card that needs to be replaced, noticing which goes where.
- 3 Remove the cables from the opening in the plastic front.
- 4 With two hands, gently pull out the card.
- 5 Gently slide the new card into the unit. Give it gentle push on the last centimeter so that it enters the backplane connector properly. Avoid pushing on the front connectors, push only on the plastic parts at the top and bottom.
- 6 Plug the interface cables into the card.

To Replace or Install a New CPU Card

- 1 Power off the Spectralink DECT Server 2500 completely.
- 2 Ensure the Spectralink DECT Server 2500 unit is properly earthed.

- 3** Unplug all interface cables on the card.
- 4** Remove the cables from the opening in the plastic front.
- 5** With two hands, gently pull out the card.
- 6** Gently slide the new card into the unit. Give it gentle push on the last centimeter so that it enters the backplane connector properly. Avoid pushing on the front connectors, push only on the plastic parts at the top and bottom.
- 7** Plug the interface cables into the card.
- 8** Connect power and reboot the unit.

Replacing the Backplane

The backplane cannot be replaced on-site. The Spectralink DECT Server 2500 will have to be returned for repair or be replaced with a new one. If a new Spectralink DECT Server 2500 is to be installed, you can move the cards from the faulty Spectralink DECT Server 2500 to the new one.

Chapter 3: Regulatory Notices

This section contains important safety regulations for the SPECTRALINK DECT Server 8000.

International Regulatory and Product Information

United States Federal Communication Commission (FCC)

Part 15: Class A Statement. This equipment has been tested and found to comply with the limits for a Class A digital device, pursuant to Part 15 of the FCC Rules. Test limits are designed to provide reasonable protection against harmful interference when the equipment is operated in a commercial environment.

This equipment generates, uses and can radiate radio-frequency energy and, if not installed and used in accordance with the instruction manuals, may cause harmful interference to radio communications. Operation of this equipment in a residential area is likely to cause harmful interference, in which case the user will be required to correct the interference at his or her own expense.

United States Safety Construction Details:

- All connections are indoor only.
- No direct connections to public networks.
- Unit is intended for RESTRICTED ACCESS LOCATION.
- Unit is to be installed in accordance with the National Electrical Code.
- The branch circuit overcurrent protection shall be rated 20 A for the AC system.
- This equipment has a maximum operating ambient of 40°C. The ambient temperature in the rack shall not exceed this temperature

CE Mark R&TTE Directive

SPECTRALINK declares that the SPECTRALINK DECT Server 8000 is in conformity with the following relevant harmonized standards:

EN 60950-1:2006 + A11:2009 + A1:2010

EN 55022:2006 + A1:2007

EN 55024:1998, A1:2002, A2:2003

Following the provisions of the Council Directive 1999/CE on radio and telecommunication terminal equipment and the recognition of its conformity.



This SPECTRALINK product has been marked with the CE mark. This mark indicates compliance with EEC Directives 89/336/EEC, 73/23/EEC 1999/5/EC. A full copy of the Declaration of Conformity can be obtained from SPECTRALINK Europe ApS, Langmarksvej 34, 8700 Horsens, Denmark.



The WEEE Marking on this equipment indicates that the product must not be disposed of with unsorted waste, but must be collected separately.

Canadian Department of Communications

This Class [A] digital apparatus complies with Canadian ICES-003.

Notice: The Industry Canada label identifies certified equipment. This certification means that the equipment meets telecommunication network protective, operational and safety requirements as prescribed in the appropriate Terminal Equipment Technical Requirements document(s). The Department does not guarantee the equipment will operate to the user's satisfaction.

Before installing this equipment, users should ensure that it is permissible to be connected to the facilities of the local telecommunications company. The equipment must also be installed using an acceptable method of connection. The customer should be aware that compliance with the above conditions may not prevent degradation of service in some situations. Repairs to certified equipment malfunctions, may give the telecommunications company causes to request the user to disconnect the equipment.

Users should ensure for their own protection that the electrical ground connections of the power utility, telephone lines and internal metallic water pipe system, if present, are connected together. This precaution may be particularly important in rural areas.

Caution: Users should not attempt to make such connections themselves, but should contact the appropriate electric inspection authority, or electrician, as appropriate.

Important Safety Instructions and Product Information

Before using your telephone equipment, you should always follow basic safety instruction to reduce the risk of fire, electrical shock and injury to persons, and damage to property.

- 1 Read and understand all instructions
- 2 Follow all warnings and instructions including those marked on the product
- 3 Unplug this product before cleaning. Do not use liquid cleaners or aerosol cleaners. Use damp cloth for cleaning
- 4 Do not install the telephone equipment in the bathroom or near a wash bowl, kitchen sink, or laundry tub, in a wet basement, or near a swimming pool
- 5 The product should be operated only from the type of power source indicated on the instructions. If you are not sure of the type of power supply, consult your dealer or local power company.
- 6 Do not overload wall outlets and extension cords as this can result in fire or electrical shock.
- 7 Never push objects of any kind into this product through cabinet slots as they may touch dangerous voltage points or short out parts that could result in fire, electrical shock, or injury. Never spill liquid of any kind into this product.

- 8 To reduce the risk of electrical shock or burns, do not disassemble this product. Opening or removing covers may expose you to dangerous voltages, dangerous electrical current, or other risks. Incorrect reassemble can cause electrical shock when the appliance is subsequently used. If the product need repair, consult your dealer.
- 9 This product does not support connections to outside plant.
- 10 Refer servicing to qualified service personnel under the following conditions:
 - If liquid has been spilled into the product
 - If the product has been exposed to rain or water
 - If the product does not operate normally when following the operating instructions in the manual. Adjust only those controls that are covered by the operation instructions. Improper adjustment of other controls may result in damage and will often require extensive work by qualified service personnel to restore the product to normal operation.
 - If the product has been dropped or cabinet has been damaged
 - If the product exhibits a distinct change in performance

Warning

- 1 Avoid using telephone during an electrical storm. There may be a risk of electrical shock from lightning
- 2 Do not use the telephone to report a gas leak in the vicinity of the leak
- 3 Do not place the unit near microwave ovens, radio equipment, or non-ground connected televisions. These appliances may cause electrical interference to the base or handset
- 4 Installation must be performed in accordance with all relevant national wiring rules
- 5 Plug acts as Disconnect Device - The socket outlet to which this apparatus is connected must be installed near the equipment and must always be readily accessible
- 6 The system will not operate in the event of a blackout. Please keep a backup phone for emergencies

Intrinsic safety

Do not install the unit in conditions where there is a danger of electrically ignited explosions.

Exposure to Sunlight, Heat and Moisture

Do not expose the unit to direct sunlight for long periods. Keep away from excessive heat and moisture.

Spare Parts and Accessories

Use only approved spare parts and accessories. The operation of non-approved parts cannot be guaranteed and may even cause damage.

RF Compliance Information

The users manual or instruction manual for an intentional or unintentional radiator shall caution the user that changes or modifications not expressly approved by the party responsible for compliance could void the user's authority to operate the equipment.

NOTICES

FCC Note: This device complies with Part 15 of the FCC rules. Operation is subject to the following two conditions: (1) This device may not cause harmful interference, and (2) this device must accept any interference received, including interference that may cause undesired operation.

IC Note: Operation is subject to the following two conditions: (1) This device may not cause interference, and (2) this device must accept any interference, including interference that may cause undesired operation of the device. The term "IC:" before the certification /registration number only signifies that the Industry Canada technical specifications were met.

Privacy of communications may not be ensured when using this telephone.

Information to user: The users manual or instruction manual for an intentional or unintentional radiator shall caution the user that changes or modifications not expressly approved by the party responsible for compliance could void the user's authority to operate the equipment.

Spectralink® Product Warranty Statement

The software included in this Product (including, without limitation, firmware and all updated thereto, including any software that may be downloaded electronically via the internet or otherwise (the "Software") is licensed, not sold. Customer shall not reverse compile, disassemble or otherwise reverse engineer, embed within any other software product, or modify in any manner with respect thereto, the Software in whole or in part.

THE TERMS AND CONDITIONS APPLICABLE TO Spectralink'S LIMITED WARRANTY ARE AS SET FORTH BELOW (AND ARE ALSO INCLUDED IN THE DOCUMENTATION PACKAGED WITH NEW Spectralink PRODUCTS):

LIMITED WARRANTY. SPECTRALINK warrants to the end user ("Customer") that the product will be free from defects in workmanship and materials, under normal use and service, for one year, or such longer period as SPECTRALINK may announce publicly from time to time for particular products, from the date of purchase from SPECTRALINK or its authorized reseller.

SPECTRALINK's sole obligation under this express warranty shall be, at SPECTRALINK's option and expense, to repair the defective product or part, deliver to Customer an equivalent product or part to replace the defective item, or if neither of the two foregoing options is reasonably available, SPECTRALINK may, in its sole discretion, refund to Customer the purchase price paid for the defective product. All products that are replaced will become the property of SPECTRALINK. Replacement products or parts may be new or reconditioned. SPECTRALINK warrants any replaced or repaired product or part for ninety (90) days from shipment, or the remainder of the initial warranty period, whichever is longer. Products returned to SPECTRALINK must be sent prepaid and packaged appropriately for safe shipment, and it is recommended that they be insured or sent by a method that provides for tracking of the package. Responsibility for loss or damage does not transfer to SPECTRALINK until the returned item is received by

SPECTRALINK. The repaired or replaced item will be shipped to Customer, at SPECTRALINK's expense, not later than thirty (30) days after SPECTRALINK receives the defective product, and SPECTRALINK will retain risk of loss or damage until the item is delivered to Customer.

EXCLUSIONS. SPECTRALINK will not be liable under this limited warranty if its testing and examination disclose that the alleged defect or malfunction in the product does not exist or results from:

- Failure to follow SPECTRALINK's installation, operation, or maintenance instructions.
- Unauthorized product modification or alteration.
- Unauthorized use of common carrier communication services accessed through the product.
- Abuse, misuse, negligent acts or omissions of Customer and persons under Customer's control; or
- Acts of third parties, acts of God, accident, fire, lighting, power surges or outages, or other hazards.

WARRANTY EXCLUSIVE. IF A SPECTRALINK PRODUCT DOES NOT OPERATE AS WARRANTED ABOVE, CUSTOMER'S SOLE REMEDY FOR BREACH OF THAT WARRANTY SHALL BE REPAIR, REPLACEMENT, OR REFUND OF THE PURCHASE PRICE PAID, AT SPECTRALINK'S OPTION. TO THE FULL EXTENT ALLOWED BY LAW, THE FOREGOING WARRANTIES AND REMEDIES ARE EXCLUSIVE AND ARE IN LIEU OF ALL OTHER WARRANTIES, TERMS, OR CONDITIONS,

EXPRESS OR IMPLIED, EITHER IN FACT OR BY OPERATION OF LAW, STATUTORY OR OTHERWISE, INCLUDING WARRANTIES, TERMS, OR CONDITIONS OF MERCHANTABILITY, FITNESS FOR A PARTICULAR PURPOSE, SATISFACTORY QUALITY, CORRESPONDENCE WITH DESCRIPTION, AND NON-INFRINGEMENT, ALL OF WHICH ARE EXPRESSLY DISCLAIMED. SPECTRALINK NEITHER ASSUMES NOR AUTHORIZES ANY OTHER PERSON TO ASSUME FOR IT ANY OTHER LIABILITY IN CONNECTION WITH THE SALE, INSTALLATION, MAINTENANCE OR USE OF ITS PRODUCTS.

SUPPORT & SERVICE AGREEMENTS. If you purchased your product from a SPECTRALINK Authorized Reseller, contact the Authorized Reseller for information about support and service agreements applicable to your product. For information on SPECTRALINK service, go to the SPECTRALINK web site www.spectralink.com, products and services menu, or call 1-800-765-9266, outside the US call 1-

408-526-9000, or your local SPECTRALINK Office, as listed on the SPECTRALINK Web site.

LIMITATION OF LIABILITY. TO THE FULL EXTENT ALLOWED BY LAW, SPECTRALINK EXCLUDES FOR ITSELF AND ITS SUPPLIERS ANY LIABILITY, WHETHER BASED IN CONTRACT OR TORT (INCLUDING NEGLIGENCE), FOR INCIDENTAL, CONSEQUENTIAL, INDIRECT, SPECIAL, OR PUNITIVE DAMAGES OF ANY KIND, OR FOR LOSS OF REVENUE OR PROFITS, LOSS OF BUSINESS, LOSS OF INFORMATION OR DATA, OR OTHER FINANCIAL LOSS ARISING

OUT OF OR IN CONNECTION WITH THE SALE, INSTALLATION, MAINTENANCE, USE, PERFORMANCE, FAILURE, OR INTERRUPTION OF ITS PRODUCTS, EVEN IF SPECTRALINK OR ITS AUTHORIZED RESELLER HAS BEEN ADVISED OF THE POSSIBILITY OF SUCH DAMAGES, AND LIMITS ITS LIABILITY TO REPAIR, REPLACEMENT, OR REFUND

OF THE PURCHASE PRICE PAID, AT SPECTRALINK'S OPTION. THIS DISCLAIMER OF LIABILITY FOR DAMAGES WILL NOT BE AFFECTED IF ANY REMEDY PROVIDED HEREIN SHALL FAIL OF ITS ESSENTIAL PURPOSE.

DISCLAIMER. Some countries, states, or provinces do not allow the exclusion or limitation of implied warranties or the limitation of incidental or consequential damages for certain products supplied to consumers, or the limitation of liability for personal injury, so the above limitations and exclusions may be limited in their application to you. When the implied warranties are not allowed to be excluded in their entirety, they will be limited to the duration of the applicable written warranty. This warranty gives you specific legal rights which may vary depending on local law.

GOVERNING LAW. This Limited Warranty and Limitation of Liability shall be governed by the laws of the State of California, U.S.A., and by the laws of the United States, excluding their conflicts of laws principles. The United Nations Convention on Contracts for the International Sale of Goods is hereby excluded in its entirety from application to this Limited Warranty and Limitation of Liability.

END-USER LICENSE AGREEMENT FOR SPECTRALINK SOFTWARE

IMPORTANT - READ CAREFULLY BEFORE USING THE SOFTWARE PRODUCT:

This End-User License Agreement ("Agreement") is a legal agreement between you (either an individual or a single entity) and SPECTRALINK, B.V for the SPECTRALINK® SOFTWARE PRODUCT licensed by SPECTRALINK, B.V in Europe, the Middle East, Africa, and Asia Pacific, or the SPECTRALINK SOFTWARE PRODUCT licensed by SPECTRALINK, Inc. in the rest of the world (collectively referred to herein as "SPECTRALINK"). The SOFTWARE PRODUCT includes computer software as attached hereto and may include associated media, printed materials, and "online" or electronic documentation ("SOFTWARE PRODUCT"). By clicking "I agree" or by installing, copying, or otherwise using the SOFTWARE PRODUCT, you agree to be bound by the terms of this Agreement. If you do not agree to the terms of this Agreement, do not install or use the SOFTWARE PRODUCT, and return it to your place of purchase for a full refund. The SOFTWARE PRODUCT is protected by copyright laws and international copyright treaties, as well as other intellectual property laws and treaties. The SOFTWARE PRODUCT is licensed (not sold) to you, and its use is subject to the terms of this Agreement.

1. GRANT OF LICENSE.

Subject to the terms of this Agreement, SPECTRALINK grants to you a non-exclusive license to install and use the SOFTWARE PRODUCT on the SPECTRALINK product with which this SOFTWARE PRODUCT is supplied (the "PRODUCT"). You may use the SOFTWARE PRODUCT only in connection with the use of the PRODUCT. You are not permitted to lease, rent, distribute or sublicense the SOFTWARE PRODUCT or to use the SOFTWARE PRODUCT in a time-sharing arrangement or in any other unauthorized manner. Further, no license is granted to you in the human readable code of the SOFTWARE PRODUCT (source code). Except as provided below, this License Agreement does not grant you any rights to patents, copyrights, trade secrets, trademarks, or any other rights in respect to the SOFTWARE PRODUCT.

2. DESCRIPTION OF OTHER RIGHTS AND LIMITATIONS.

2.1 Limitations on Reverse Engineering, Decompilation, and Disassembly. You may not reverse engineer, decompile, or disassemble the SOFTWARE PRODUCT, except and only to the extent that such activity is expressly permitted by applicable law notwithstanding this limitation. The SOFTWARE PRODUCT is licensed as a single product. Its component parts may not be separated for use on more than one PRODUCT.

2.2 Back-up. Except as expressly provided for under this Agreement you may not copy the SOFTWARE PRODUCT; except, however, you may keep one copy of the SOFTWARE PRODUCT and, if applicable, one copy of any previous version, for back-up purposes, only to be used in the event of failure of the original. All copies of the SOFTWARE PRODUCT must be marked with the proprietary notices provided on the original SOFTWARE PRODUCT. You may not reproduce the supporting documentation accompanying the SOFTWARE PRODUCT.

2.3 Modifications. You may not modify, translate or create derivative works of the SOFTWARE PRODUCT.

2.4 Proprietary Notices. You may not remove or obscure any proprietary notices on or in the SOFTWARE PRODUCT or the supporting documentation.

2.5 Software Transfer. You may permanently transfer all of your rights under this Agreement, provided you retain no copies, you transfer all of the SOFTWARE PRODUCT (including all component parts, the media and printed materials, any upgrades, this Agreement, and, if applicable, the Certificate of Authenticity), and the recipient agrees to the terms of this Agreement. If the SOFTWARE PRODUCT is an upgrade, any transfer must include all prior versions of the SOFTWARE PRODUCT. However, if the SOFTWARE PRODUCT is marked "Not for Resale" or "NFR", you may not resell it or otherwise transfer it for value.

2.6 Copyright. All title and copyrights in and to the SOFTWARE PRODUCT (including but not limited to any images, photographs, animations, video, audio, music, text, and "applets" incorporated into the SOFTWARE PRODUCT), the accompanying printed materials, and any copies of the SOFTWARE PRODUCT are owned by SPECTRALINK or its suppliers. The SOFTWARE PRODUCT is protected by copyright laws and international treaty provisions. Title, ownership rights, and intellectual property rights in the SOFTWARE PRODUCT shall remain in SPECTRALINK or its suppliers. Title and related rights in the content accessed through the SOFTWARE PRODUCT is the property of such content owner and may be protected by applicable law. This Agreement gives you no rights in such content.

2.7 Confidentiality. The SOFTWARE PRODUCT contains valuable proprietary information and trade secrets of SPECTRALINK and its suppliers and you shall protect the confidentiality of, and avoid disclosure and unauthorized use of, the SOFTWARE PRODUCT.

2.8 Dual-Media Software. You may receive the SOFTWARE PRODUCT in more than one medium. Regardless of the type or size of medium you receive, you may use only one medium that is appropriate for your single PRODUCT. You may not use or install the other medium on another PRODUCT.

2.9 Reservation. SPECTRALINK reserves all rights in the SOFTWARE PRODUCT not expressly granted to you in this Agreement.

3. SUPPORT SERVICES.

SPECTRALINK may provide you with support services related to the SOFTWARE PRODUCT ("SUPPORT SERVICES "). Use of SUPPORT SERVICES is governed by the SPECTRALINK policies and programs described in the SPECTRALINK - provided materials. Any

supplemental software code provided to you as part of the SUPPORT SERVICES is considered part of the SOFTWARE PRODUCT and is subject to the terms and conditions of this Agreement. With respect to technical information you provide to SPECTRALINK as part of the SUPPORT SERVICES, SPECTRALINK may use such information for its business purposes, including for product support and development. SPECTRALINK will not utilize such technical information in a form that personally identifies you.

4. TERMINATION.

Without prejudice to any other rights, SPECTRALINK may terminate this Agreement if you fail to comply with any of the terms and conditions of this Agreement. In such event, you must destroy all copies of the SOFTWARE PRODUCT and all of its component parts. You may terminate this Agreement at any time by destroying the SOFTWARE PRODUCT and all of its component parts.

5. UPGRADES.

If the SOFTWARE PRODUCT is labeled as an upgrade, you must be properly licensed to use the software identified by SPECTRALINK as being eligible for the upgrade in order to use the SOFTWARE PRODUCT. A SOFTWARE PRODUCT labeled as an upgrade replaces and/or supplements the software that formed the basis for your eligibility for the upgrade. You may use the resulting upgraded SOFTWARE PRODUCT only in accordance with the terms of this Agreement. If the SOFTWARE PRODUCT is an upgrade of a component of a package of software programs that you licensed as a single product, the SOFTWARE PRODUCT may be used and transferred only as part of that single SOFTWARE PRODUCT package and may not be separated for use on more than one PRODUCT.

6. WARRANTY AND WARRANTY EXCLUSIONS.

6.1 Limited Warranty. SPECTRALINK warrants that (a) the SOFTWARE PRODUCT will perform substantially in accordance with the accompanying documentation for a period of ninety (90) days from the date of receipt by you, and (b) any SUPPORT SERVICES provided by SPECTRALINK shall be substantially as described in applicable written materials provided to you by SPECTRALINK, and SPECTRALINK support engineers will make commercially reasonable efforts to solve any problem issues. SPECTRALINK does not warrant that your use of the SOFTWARE PRODUCT will be uninterrupted or error free, or that all defects in the SOFTWARE PRODUCT will be corrected. SPECTRALINK's sole obligation under this express warranty shall be, at SPECTRALINK's option and expense, to refund the purchase price paid by you for any defective software product which is returned to SPECTRALINK with a copy or your receipt, or to replace any defective media with software which substantially conforms to applicable SPECTRALINK published specifications. Any replacement SOFTWARE PRODUCT will be warranted for the remainder of the original warranty period or thirty (30) days, whichever is longer.

6.2 Warranties Exclusive. IF THIS SOFTWARE PRODUCT DOES NOT OPERATE AS WARRANTED ABOVE, YOUR SOLE REMEDY FOR BREACH OF THAT WARRANTY SHALL BE REPAIR, REPLACEMENT, OR REFUND OF THE PURCHASE PRICE PAID, AT SPECTRALINK'S OPTION. TO THE FULL EXTENT ALLOWED BY LAW, THE FOREGOING WARRANTIES AND REMEDIES ARE EXCLUSIVE AND ARE IN LIEU OF ALL OTHER WARRANTIES, TERMS, OR CONDITIONS, EXPRESS OR IMPLIED, EITHER IN FACT OR BY OPERATION OF LAW, STATUTORY OR OTHERWISE, INCLUDING WARRANTIES, TERMS, OR CONDITIONS OF MERCHANTABILITY, FITNESS FOR A PARTICULAR PURPOSE, SATISFACTORY QUALITY, CORRESPONDENCE WITH DESCRIPTION, AND NON-INFRINGEMENT, ALL OF WHICH ARE EXPRESSLY DISCLAIMED. SPECTRALINK

NEITHER ASSUMES NOR AUTHORIZES ANY OTHER PERSON TO ASSUME FOR IT ANY OTHER LIABILITY IN CONNECTION WITH THE SALE, INSTALLATION, MAINTENANCE OR USE OF THIS SOFTWARE PRODUCT. SPECTRALINK SHALL NOT BE LIABLE UNDER THIS WARRANTY IF ITS TESTING AND EXAMINATION DISCLOSE THAT THE ALLEGED DEFECT OR MALFUNCTION IN THE SOFTWARE PRODUCT DOES NOT EXIST OR WAS CAUSED BY YOUR OR ANY THIRD PERSON'S MISUSE, NEGLIGENCE, IMPROPER INSTALLATION OR TESTING, UNAUTHORIZED ATTEMPTS TO MODIFY THE PRODUCT, OR ANY OTHER CAUSE BEYOND THE RANGE OF THE INTENDED USE, OR BY ACCIDENT, FIRE, LIGHTNING, POWER CUTS OR OUTAGES, OTHER HAZARDS, OR ACTS OF GOD.

7. LIMITATION OF LIABILITY.

TO THE MAXIMUM EXTENT PERMITTED BY APPLICABLE LAW, IN NO EVENT SHALL SPECTRALINK OR ITS SUPPLIERS BE LIABLE FOR ANY SPECIAL, INCIDENTAL, INDIRECT, OR CONSEQUENTIAL DAMAGES WHATSOEVER (INCLUDING, WITHOUT LIMITATION, DAMAGES FOR LOSS OF BUSINESS PROFITS, BUSINESS INTERRUPTION, LOSS OF BUSINESS INFORMATION, OR ANY OTHER PECUNIARY LOSS) ARISING OUT OF THE USE OF OR INABILITY TO USE THE SOFTWARE PRODUCT OR THE PROVISION OF OR FAILURE TO PROVIDE SUPPORT SERVICES, EVEN IF SPECTRALINK HAS BEEN ADVISED OF THE POSSIBILITY OF SUCH DAMAGES. IN ANY CASE, SPECTRALINK'S ENTIRE LIABILITY SHALL BE LIMITED TO THE GREATER OF THE AMOUNT ACTUALLY PAID BY YOU FOR THE SOFTWARE PRODUCT OR U.S. \$5.00. PROVIDED, HOWEVER, IF YOU HAVE ENTERED INTO A SPECTRALINK SUPPORT SERVICES AGREEMENT, SPECTRALINK'S ENTIRE LIABILITY REGARDING SUPPORT SERVICES SHALL BE GOVERNED BY THE TERMS OF THAT AGREEMENT.

8. DISCLAIMER.

Some countries, states, or provinces do not allow the exclusion or limitation of implied warranties or the limitation of incidental or consequential damages for certain products supplied to consumers, or the limitation of liability for personal injury, so the above limitations and exclusions may be limited in their application to you. When the implied warranties are not allowed to be excluded in their entirety, they will be limited to the duration of the applicable written warranty. This warranty gives you specific legal rights which may vary depending on local law.

9. EXPORT CONTROLS.

The SOFTWARE PRODUCT may not be downloaded or otherwise exported or re-exported (i) into (or to a national or resident of) Cuba, Iraq, Libya, North Korea, Yugoslavia, Iran, Syria, Republic of Serbia, or any other country to which the U.S. has embargoed goods; or (ii) to anyone on the U.S. Treasury Department's list of Specially Designated Nationals or the U.S. Commerce Department's Table of Denial Orders. By downloading or using the SOFTWARE PRODUCT, you are agreeing to the foregoing and you are representing and warranting that you are not located in, under the control of, or a national or resident of any such country or on any such list. If you obtained this SOFTWARE PRODUCT outside of the United States, you are also agreeing that you will not export or re-export it in violation of the laws of the country in which it was obtained.

10. MISCELLANEOUS.

10.1 Governing Law. This Agreement shall be governed by the laws of the State of California as such laws are applied to agreements entered into and to be performed entirely within California between California residents, and by the laws of the United States. The United Nations Convention on Contracts for the International Sale of Goods (1980) is hereby excluded in its entirety from application to this Agreement.

10.2 General. This Agreement represents the complete agreement concerning this license and may amended only by a writing executed by both parties. If any provision of this Agreement is held to be unenforceable, such provision shall be reformed only to the extent necessary to make it enforceable.

10.3 Contact. If you have any questions concerning this Agreement, or if you desire to contact SPECTRALINK for any reason, please contact the SPECTRALINK office serving your country.

10.4 U.S. Government Restricted Rights. The SOFTWARE PRODUCT and documentation are provided with RESTRICTED RIGHTS. The SOFTWARE PRODUCT programs and documentation are deemed to be "commercial computer software" and "commercial computer software documentation", respectively, pursuant to DFAR Section 227.7202 and FAR 12.212(b), as applicable. Any use, modification, reproduction, release, performance, display or disclosure of the SOFTWARE PRODUCT programs and/or documentation by the U.S. Government or any of its agencies shall be governed solely by the terms of this Agreement and shall be prohibited except to the extent expressly permitted by the terms of this Agreement. Any technical data provided that is not covered by the above provisions is deemed to be "technical data-commercial items" pursuant to DFAR Section 227.7015(a). Any use, modification, reproduction, release, performance, display or disclosure of such technical data shall be governed by the terms of DFAR Section 227.7015(b).

Appendix A: RJ45 Wiring

The following table shows the assignments of wire pairs to plug and socket pins of the RJ45 cable.

Table 1 RJ45 cable wiring

Pin	Pair	Wiring	Connector A	Connector B	Connector C	Connector D
1	2	tip	1	5	9	13
2	2	ring	1	5	9	13
3	3	tip	2	6	10	14
4	1	ring	0	4	8	12
5	1	tip	0	4	8	12
6	3	ring	2	6	10	14
7	4	tip	2	7	11	15
8	4	ring	3	7	11	15

Appendix B: Cable Connections

Analogue Interface Card

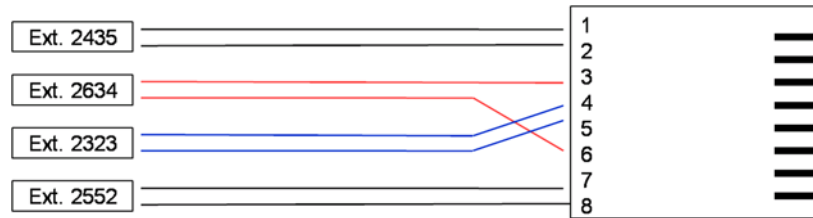

Extensions from
the PBX

J5 to the Spectralink DECT Server 2500

Clip facing DOWN

Base Station Interface Card

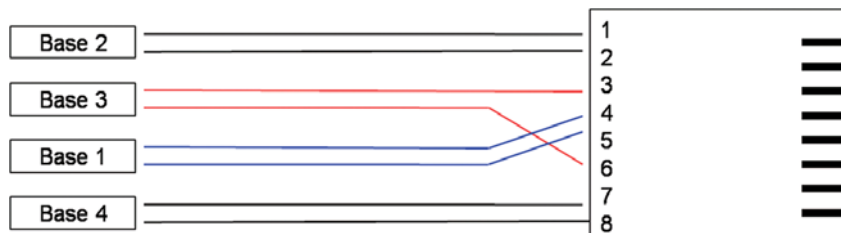

Base Station

RJ45 to the Spectralink DECT Server 2500

Clip facing DOWN

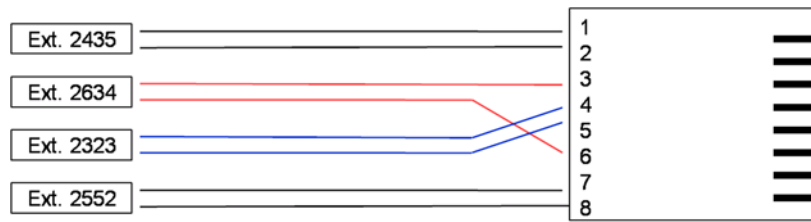

Base Station Interface Card

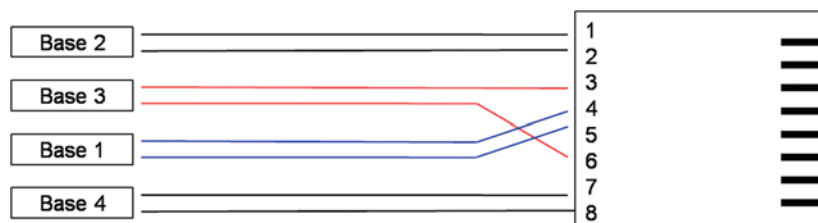

Base stations

RJ45 Pins

Figure 1 RJ45 Pin Position

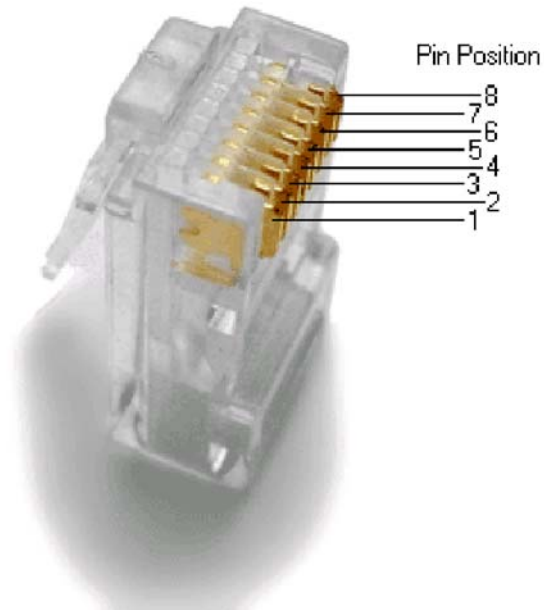

Tables

Table 1	Physical Dimensions	3
Table 2	Power Supply	3
Table 3	Power Consumption	3
Table 4	Environment	4
Table 1	RJ45 cable wiring	28

Figures

Figure 1	CPU Card Connections	6
Figure 2	RJ45 Connections for Base Stations	6
Figure 3	RJ45 Connections for AB Lines	7
Figure 4	Media Resource Card Connection	7
Figure 5	Wall mounting method 1	9
Figure 6	Wall mounting method 2	9
Figure 7	Wall mounting method 3	10
Figure 8	Installing Interface Cards	12
Figure 9	Installing CPU card	13
Figure 10	Harnessing cables to the back and out	14
Figure 11	Harnessing cables to the side and out.	15
Figure 1	RJ45 Pin Position	31